

RELEASE

DATE:

COMPANY:

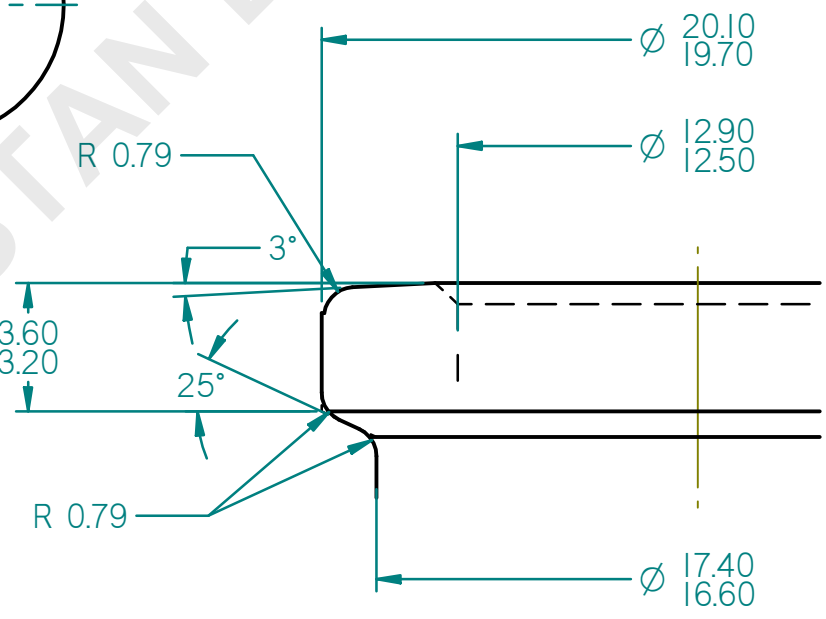
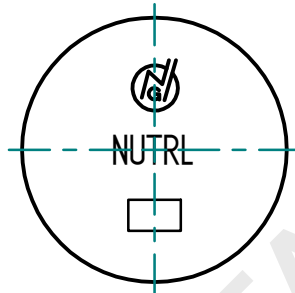
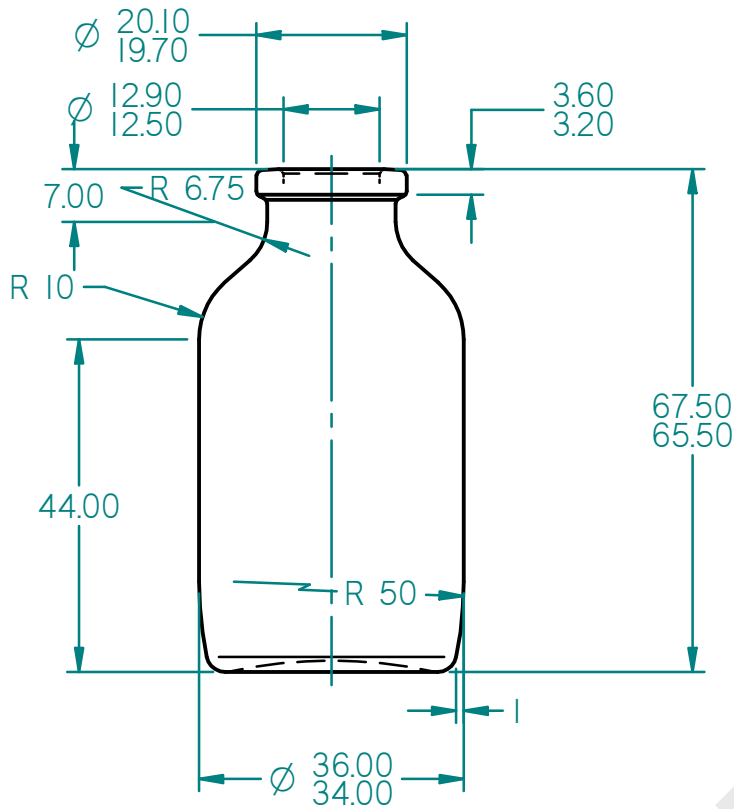

FINISH : 20 mm STD.

Protective note ISO 16016 observed

GENERAL TOLERANCES DIN 6129-1 (DIMENSIONS WITHOUT TOLERANCES ARE FOR REFERENCE ONLY)				FINISH: 20 mm STD.		O'FLOW CAPACITY: 36.50 - 38.50 ml		ARTICLE NO.:			
				FINISH DWG: NA		WEIGHT: 38 g Approx.		5153050100			
				FINISH MOLD NO: 910		TYPE OF GLASS: I COLOUR: FLINT					
				DATE		NAME		TITLE: <h2 style="text-align: center;">30 ml EROS - N</h2>			
				DRAWN 21/11/2013		Paresh					
				CHECKED 21/11/2013		H.B.P.					
				SCALE 1 : 1,5 : 1							
				 NEUTRAL GLASS & ALLIED INDS. PVT. LTD. MUMBAI / KOSAMBA		MOLD NO.:		DRAWING NO.:		REVISION	
						106		B 3050		0	
								SHEET		FORMAT	
								1 OF 1		A4	
REV.				CHANGE		DATE		NAME		FILE: 30 ml EROS - N.dft	